

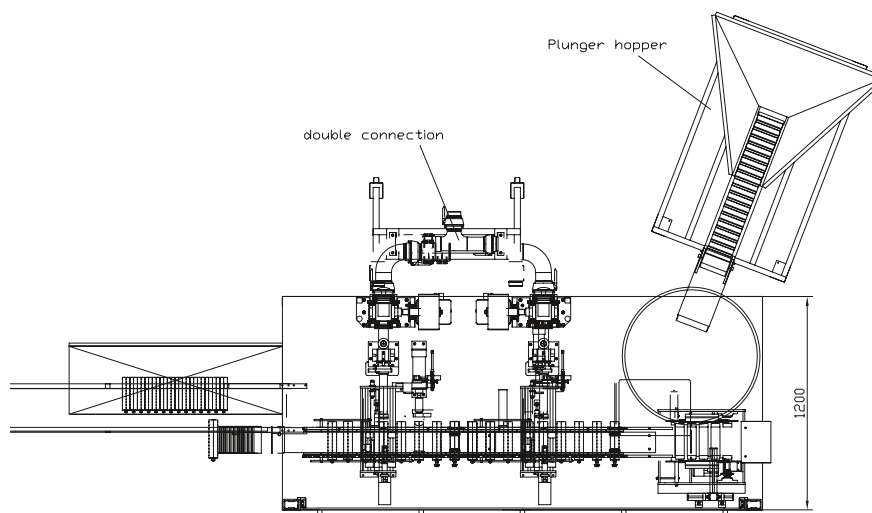

## FILLING & CLOSING MACHINES

### DOUBLE HEAD SERVO FILLER SV-2

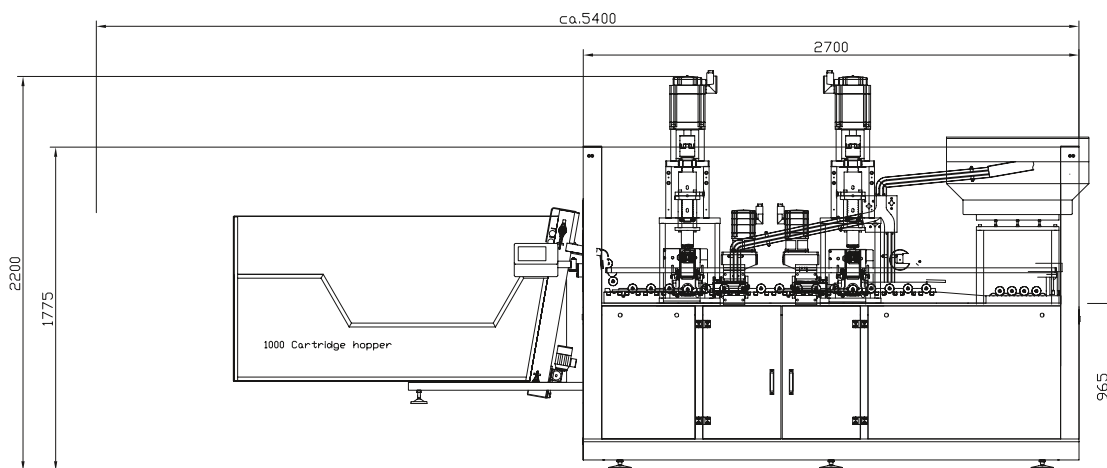

From the Fischbach machinery portfolio for cartridge filling, accessorizing and case packing.

**Fischbach KG**  
51766 Engelskirchen, Germany  
Telefon: +49 2263 609 0  
info@fischbach-fi.com

**Fischbach Ibérica, S.A.**  
17410 Sils (Girona), Spain  
Telefon: +34 972 168 487  
spain@fischbach-fi.com

**Fischbach Belgium N.V.**  
9140 Temse, Belgium  
Telefon: +32 371 096 20  
belgium@fischbach-fi.com

**Fischbach USA Inc.**  
 Elizabethtown, Kentucky, 42701 USA  
Telefon: +1 270 769 9333  
usa@fischbach-fi.com

**Fischbach Korea Co., Ltd.**  
Songpa-Gu, Seoul, Korea  
Telefon: +82 2 425 3092  
korea@fischbach-fi.com

**Fischbach (Shanghai) Co., Ltd.**  
Shanghai, China 201708  
Telefon: +86 21 6979 1423  
china@fischbach-fi.com

**Fischbach U.K. Ltd.**  
Cheshire WA7 1SN, Great Britain  
Telefon: +44 1928 579 320  
uk@fischbach-fi.com

[www.fischbach-fi.com](http://www.fischbach-fi.com)



## FILLING & CLOSING MACHINES

### DOUBLE HEAD SERVO FILLER SV-2

**Fischbach Servo Filler SV-2: Automatic filling, closing and marking of 100 cartridges per minute with two filling heads.**

#### FEATURES

- > Precise, servo controlled volume dosing. Superior dosing accuracy at various viscosities.
- > Nine axis SERVO operation allows adaptability to the widest variety of sealants and adhesives.
- > Superior process reliability at high operating speeds due to vacuum supported cartridge transport system.
- > Horizontal, closed loop fill sequence provides high speed air-free fill.
- > Filling plastic, aluminum or cardboard cartridges with or without nozzle.
- > Cartridges fed from ground-level magazine holding 1000 standard cartridges.
- > Linear sensor controlled plunger insertion for 100% accurate positioning.
- > Quick release plunger station to aid in cleaning, maintenance and changeover.
- > Metering chain plunger sorter ensures consistent reliable performance for all plunger types.
- > Advanced, touch screen operator interface for fast and easy access to all machine functions.
- > One-piece sliding doors allow efficient cleaning and maintenance.

#### OPTIONS

- > Fischbach MultiMix, for blending a base and additives, can be integrated.
- > Case Packer Fi-CH 100 and Palletizer Fi-PA, to create a fully automated, high performance line.

#### TECHNICAL DATA

Type: Double Head Cartridge Filling and Closing Machine SV-2

Output: 100 cartridges per minute at 310 ml

Dosing: Volumetric

Dosing Range: 240 ml to 500 ml

Connecting height at Product Infeed: 1000 mm or variable through optional height adjustment

Voltage: 3 x 400 V, 50 Hz or as requested

Control: Siemens Simotion D

Power: 20 KW/50 Amps

Air Pressure: 5 bar minimum (75 psi)

Air Consumption: 70 NL per minute

Weight: 2.200 kg



**Fischbach KG**  
51766 Engelskirchen, Germany  
Telefon: +49 2263 609 0  
info@fischbach-fi.com

**Fischbach Ibérica, S.A.**  
17410 Sils (Girona), Spain  
Telefon: +34 972 168 487  
spain@fischbach-fi.com

**Fischbach Belgium N.V.**  
9140 Temse, Belgium  
Telefon: +32 371 096 20  
belgium@fischbach-fi.com

**Fischbach USA Inc.**  
Elizabethtown, Kentucky, 42701 USA  
Telefon: +1 270 769 9333  
usa@fischbach-fi.com

**Fischbach Korea Co., Ltd.**  
Songpa-Gu, Seoul, Korea  
Telefon: +82 2 425 3092  
korea@fischbach-fi.com

**Fischbach (Shanghai) Co., Ltd.**  
Shanghai, China 201708  
Telefon: +86 21 6979 1423  
china@fischbach-fi.com

**Fischbach U.K. Ltd.**  
Cheshire WA7 1SN, Great Britain  
Telefon: +44 1928 579 320  
uk@fischbach-fi.com

[www.fischbach-fi.com](http://www.fischbach-fi.com)