

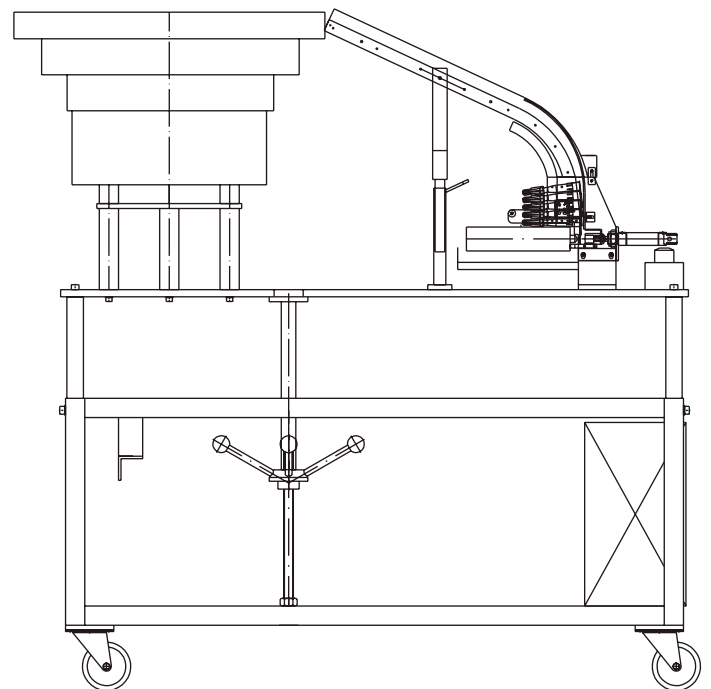

SPECIAL MACHINES

CLIP NOZZLE MOUNTER CDM-40

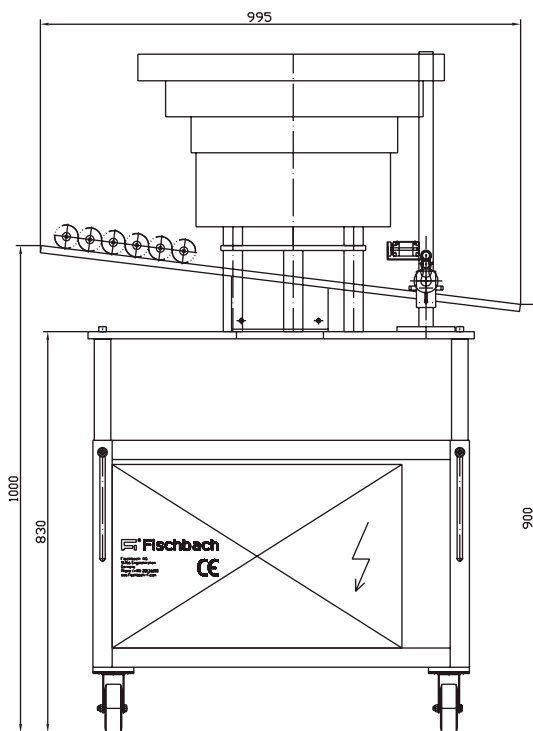

From the Fischbach machinery line for cartridge filling, accessorizing and case packing.

Fischbach KG
51766 Engelskirchen, Germany
Telefon: +49 (0) 2263 6090
info@fischbach-fi.com

Fischbach Ibérica, S.A.
17410 Sils (Girona), Spain
Telefon: +34-972-16 84 87
spain@fischbach-fi.com

Fischbach Belgium N.V.
9140 Temse, Belgium
Telefon: +32-3-710 96 20
belgium@fischbach-fi.com

Fischbach USA Inc.
Elizabethtown, Kentucky, 42701 USA
Telefon: +1-270-7 69 93 33
usa@fischbach-fi.com

Fischbach Korea Co., Ltd.
Songpa-Gu, Seoul, Korea
Telefon: +82 2 425 3092
korea@fischbach-fi.com

Fischbach (Shanghai) Co., Ltd.
Shanghai, China 201708
Telefon: +86-21-6979-1423
china@fischbach-fi.com

Fischbach U.K. Ltd.
Cheshire WA7 1SN, Great Britain
Telefon: +44-1928-579320
uk@fischbach-fi.com

www.fischbach-fi.com



SPECIAL MACHINES

CLIP NOZZLE MOUNTER CDM-40

Fischbach CDM-40: Cartridge accessorizing with clip nozzle in a fully automatic operating cycle

FEATURES

- > Processes all kinds of plastic, aluminium or cardboard cartridges.
- > Useable as individual machine or part of a filling and packing line.
- > Cartridge accessorizing with clip nozzle in a fully automatic operating cycle.
- > The compact modular design enables the machine to be optimally adapted to customers individual packaging requirements, while taking up a minimum of space.
- > Trouble-free operation due to the latest process control.
- > Superior safety devices in compliance with the European CE Standard.

TECHNICAL DATA

Output: 35 cartridges per minute
Type of Nozzles: All standard clip nozzles
Type of Cartridges: All standard cartridges
Height adjustment: Mechanical or pneumatic
Voltage: 220 V, 50/60 Hz
Control Voltage: 24 V (internal)
Air pressure: 5 bar (75 psi)
Capacity of Clip Nozzle Magazine:
Approximately 300 clip nozzles
Weight: 300 kg
Control: PLC
Air Consumption: 120 NL per minute



Fischbach KG
51766 Engelskirchen, Germany
Telefon: +49 (0) 2263 6090
info@fischbach-fi.com

Fischbach Ibérica, S.A.
17410 Sils (Girona), Spain
Telefon: +34-972-16 84 87
spain@fischbach-fi.com

Fischbach Belgium N.V.
9140 Temse, Belgium
Telefon: +32-3-710 96 20
belgium@fischbach-fi.com

Fischbach USA Inc.
 Elizabethtown, Kentucky, 42701 USA
Telefon: +1-270-7 69 93 33
usa@fischbach-fi.com

Fischbach Korea Co., Ltd.
Songpa-Gu, Seoul, Korea
Telefon: +82 2 425 3092
korea@fischbach-fi.com

Fischbach (Shanghai) Co., Ltd.
Shanghai, China 201708
Telefon: +86-21-6979-1423
china@fischbach-fi.com

Fischbach U.K. Ltd.
Cheshire WA7 1SN, Great Britain
Telefon: +44-1928-579320
uk@fischbach-fi.com

www.fischbach-fi.com