

SV-1

High Speed Cartridge Filler SV-2

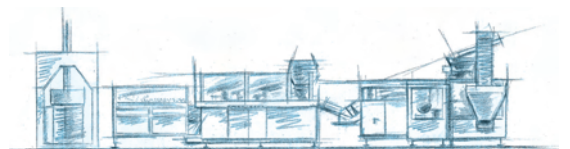

From the Fischbach machinery line for cartridge filling, accessorizing and case packing.



Fischbach Servo Filler SV-2: Automatic filling, closing and marking of 100 cartridges per minute with two filling heads.

Features

- Precise, servo controlled volume dosing. Superior dosing accuracy at various viscosities.
- Nine axis SERVO operation allows adaptability to the widest variety of sealants and adhesives.
- Superior process reliability at high operating speeds due to vacuum supported cartridge transport system.
- Horizontal, closed loop fill sequence provides high speed air-free fill.
- Filling plastic, aluminum or cardboard cartridges with or without nozzle.
- Cartridges fed from ground-level magazine holding 1000 standard cartridges.
- Linear sensor controlled plunger insertion for 100% accurate positioning.
- Quick release plunger station to aid in cleaning, maintenance and change-over.
- Metering chain plunger sorter ensures consistent reliable performance for all plunger types.
- Advanced, touch screen operator interface for fast and easy access to all machine functions.
- One-piece sliding doors allow efficient cleaning and maintenance.

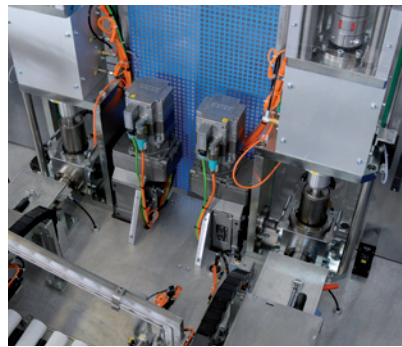

Double Servo Dosing



Color Touch Screen

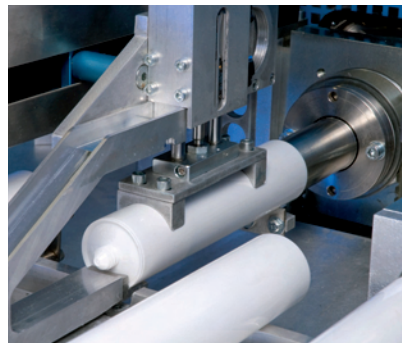

Servo Shuttle

Options

- Fischbach MultiMix, for blending a base and additives, can be integrated.
- Case Packer Fi-CH 100 and Palletizer Fi-PA, To create a fully automated, high performance line.

Technical Data

Type of Machine:	Double Head Cartridge Filling and Closing Machine SV-2
Output:	100 cartridges per minute at 310 ml
Dosing:	Volumetric
Dosing Range:	240 ml to 500 ml
Connecting height at Product Infeed:	1000 mm or variable through optional height adjustment
Voltage:	3 x 400 V, 50 Hz or as requested
Control:	Simotion D
Power	20 KW /50 Amps
Air Pressure:	5 bar minimum (75 psi.)
Air Consumption:	70 NL per minute
Weight:	2.2 tons

Single Head Filler SV-2

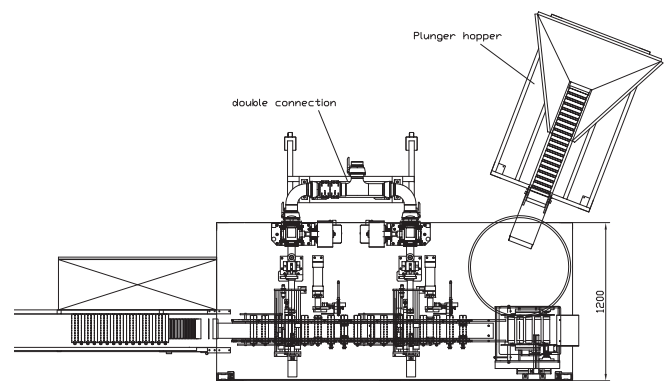
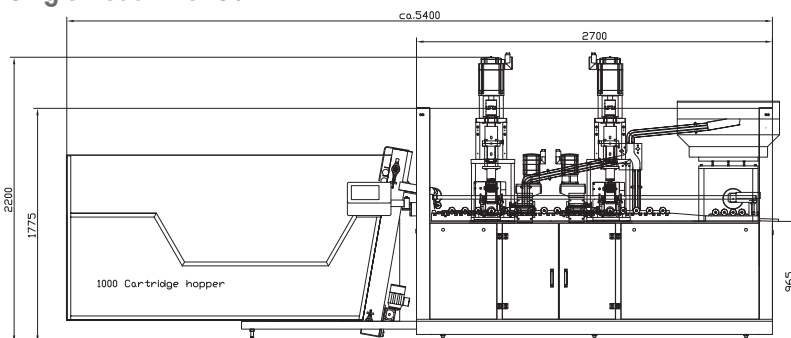

Fischbach



Fischbach KG
Büchlerhausen 18
D-51766 Engelskirchen, Germany

Fischbach Korea Co., Ltd.
Telefon: +82.2.3452.3091
Telefax: +82.2.3452.3095

Fischbach Belgium N.V.
Telefon: +32.3710.9621
Telefax: +32.3710.9631

Fischbach Ibérica, S.A.
Telefon: +34.972.168487
Telefax: +34.972.168324

www.fischbach-fi.com
Telefon: +49.2263.6090
Telefax: +49.2263.60358

Fischbach U.K. Ltd.
Telefon: +44.1928.579320
Telefax: +44.1928.579403

Fischbach USA Inc.
Telefon: +1.270.769.9333
Telefax: +1.270.769.9623

Fischbach (Shanghai) Co., Ltd.
Telefon: +8621.6979.1420
Telefax: +8621.6979.1426