

**Fi-CL**

**Semi Automatic Cartridge Case Packer Fi-CL**

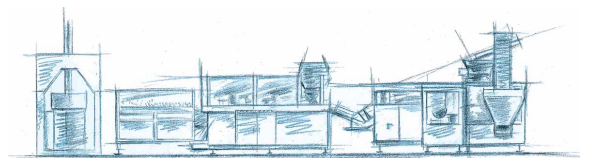

From the Fischbach machinery line for cartridge filling, accessorizing and case packing.



# Fischbach Cartridge Case Packer Fi-CL: Up to 50 cartridges per minute accessorized and packed.

## Features

- Packages all kinds of plastic, aluminium or cardboard cartridges in one or two-piece version.
- The compact modular design enables the machine to be optimally adapted to customers individual packaging requirements, while taking up a minimum of space.
- A packaging performance rate of 50 cartridges per minute with only one operator makes the Fi-CL the ideal supplement to any filling line.
- Cartridge accessorized with clip nozzles completely integrated in one automatic operating cycle.
- Program-controlled buffer magazine for 35 cartridges guarantees uninterrupted operation.
- Well designed system for easily adjusted case formats; change of format accomplished without tools within less than three minutes.
- Trouble-free operation due to latest process control and operation Interface.
- Superior safety devices in compliance with European CE-Standard.



Automatic Buffer Magazine

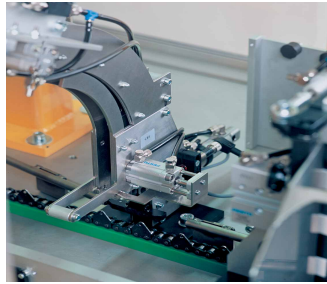

Clip-Nozzle-Station

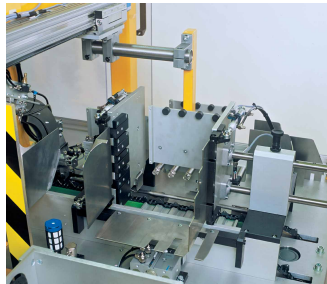

Cartridge Stacker

## Technical Data

Output:	Up to 50 cartridges per minute (depending on box format)
Types of cartridges:	All standard cartridges
Packaging formats:	2x4, 2x5, 2x6, 3x4, 3x5, 3x6, 4x4, 4x5, 4x6, 5x4, 5x5, and 5x6 cartridges per carton
Nozzle Accessorizing:	Automatic clip nozzle station (rate: 50 nozzles per minute)
Sealing of carton:	Externally - optional
Cartridge Buffer:	Standard capacity 35 cartridges
Weight:	600 kg
Voltage:	3 x 400 V, 50 Hz or as requested
Current:	300 W (800 W with clip nozzle station)
Fuses:	6 ampere
Control Voltage:	24 V (internal)
Process Control:	Siemens PLC
Air Pressure:	6 bar minimum (90 psi.)
Air Consumption:	120 NL per minute (210 NL with clip nozzle station)

## Semi Automatic Cartridge Case Packer Fi-CL

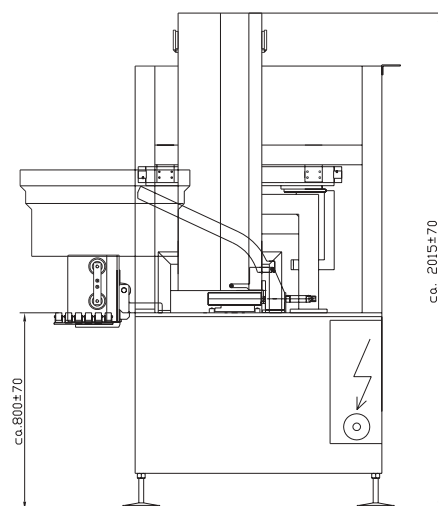
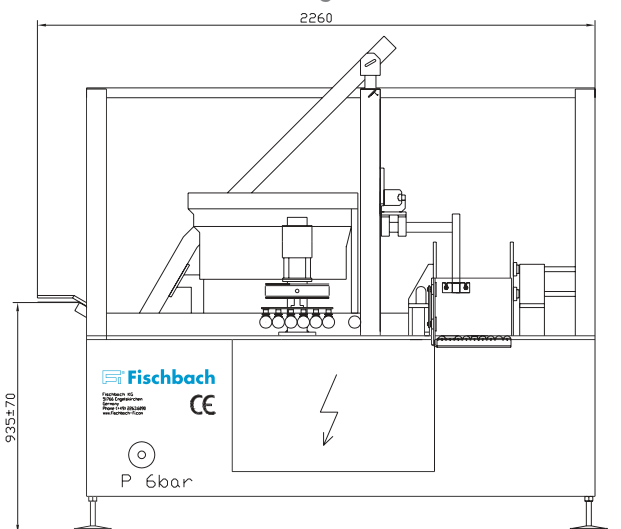

**F**® **Fischbach**



Fischbach KG  
Büchlerhausen 18  
D-51766 Engelskirchen, Germany

Fischbach Korea Co., Ltd.  
Telefon: +82.2.3452.3091  
Telefax: +82.2.3452.3095

Fischbach Belgium N.V.  
Telefon: +32.3710.9621  
Telefax: +32.3710.9631

Fischbach Ibérica, S.A.  
Telefon: +34.972.168487  
Telefax: +34.972.168324

www.fischbach-fi.com  
Telefon: +49.2263.6090  
Telefax: +49.2263.60358

Fischbach U.K. Ltd.  
Telefon: +44.1928.579320  
Telefax: +44.1928.579403

Fischbach USA Inc.  
Telefon: +1.270.769.9333  
Telefax: +1.270.769.9623

Fischbach GmbH & Co.KG  
Telefon: +49.3522.5285 0  
Telefax: +49.3522.528511