



ET-01

Automatic Cartridge Labelling System ET-01



From the Fischbach machinery line for cartridge filling, accessorizing and case packing.

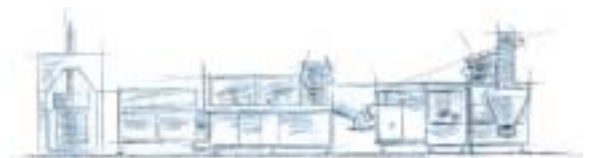

Automatic Cartridge Labelling System: 40 cartridges per minute automatically marked with self adhesive labels.

Features

- Processes plastic, aluminium or fiber cartridges; with or without integrated nozzle.
- The compact design enables the machine to be integrated in any production line, even when floor space is limited.
- Available with or without integrated TT-Printer module.
- Supports very short run length due to easy and quick label change mechanism.
- Laser sensor for cartridge indexing guarantees the highest level of accuracy and repeatability.
- Optimized cartridge spinning drive for trouble free operation with all types of standard cartridges.
- Superior safety devices in compliance with the European CE Standard.



Laser Sensor Indexing



Control Cabinet

Technical Data

Type of Machine:	Cartridge Labeling System ET-01
Rate of Operation:	40 cartridges per minute
Index Accuracy (Label):	+/- 2mm
Cartridge In-feed Height:	950 mm or variable through optional height adjustment
Cartridge Eject Height:	900 mm or variable through optional height adjustment
Voltage:	230 V/400 V, 50/60 Hz
Control:	PLC
Air Pressure:	6 bar minimum (87 psi.)

Options

- Automatic cartridge magazine with conveyor

ET-01

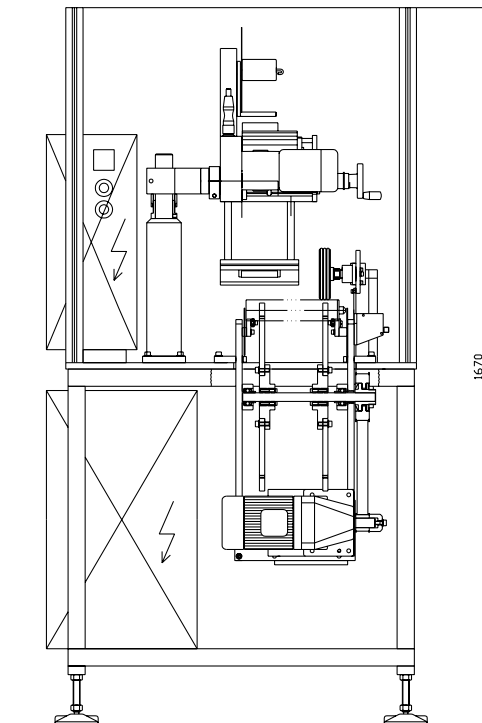
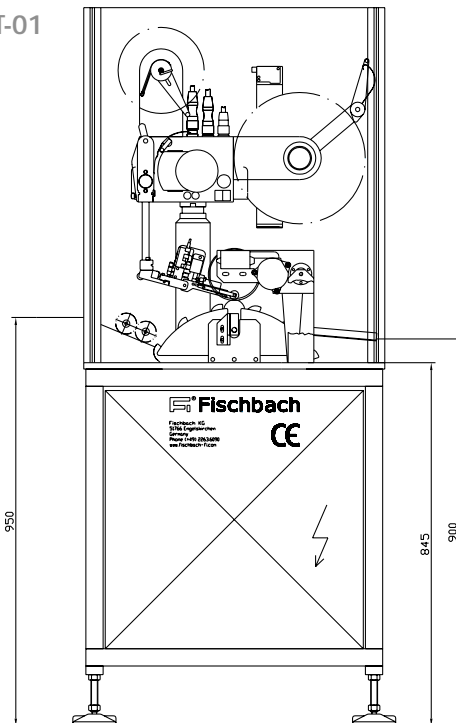

Fischbach



Fischbach KG
Büchlerhausen 18
D-51766 Engelskirchen, Germany

www.fischbach-fi.com
Telefon: +49.2263.6090
Telefax: +49.2263.60358

Fischbach Korea Co., Ltd.
Telefon: +82.2.3452.3091
Telefax: +82.2.3452.3095

Fischbach U.K. Ltd.
Telefon: +44.1928.579320
Telefax: +44.1928.579403

Fischbach Belgium N.V.
Telefon: +32.3710.9621
Telefax: +32.3710.9631

Fischbach USA Inc.
Telefon: +1.270.769.9333
Telefax: +1.270.769.9623

Fischbach Ibérica, S.A.
Telefon: +34.972.168487
Telefax: +34.972.168324

Fischbach GmbH & Co.KG
Telefon: +49.3522.5285 0
Telefax: +49.3522.528511