

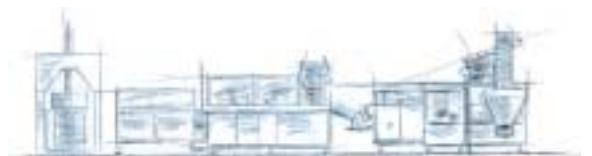

## CDM-40 Clip Nozzle Mounter CDM - 40



From the Fischbach machinery line for cartridge filling, accessorizing and case packing.



# Fischbach CDM-40: Accessorizes 35 cartridges per minute with clip nozzles.

## Features

- Processes all kinds of plastic, aluminium or cardboard cartridges.
- Useable as individual machine or part of a filling and packing line.
- Cartridge accessorizing with clip nozzle in a fully automatic operating cycle.
- The compact modular design enables the machine to be optimally adapted to customers individual packaging requirements, while taking up a minimum of space.
- Trouble-free operation due to the latest process control.
- Superior safety devices in compliance with the European CE Standard.



Clip Nozzle Mounting Station



Optimized Nozzle Feeder

## Technical Data

Output:	35 cartridges per minute
Type of Nozzles:	All standard clip nozzles
Type of Cartridges:	All standard cartridges
Height adjustment:	Mechanical or pneumatic
Voltage:	220 V, 50/60 Hz
Control Voltage:	24 V (internal)
Required Air Pressure:	5 bar (75 psi.)
Capacity of Clip Nozzle Magazine:	Approximately 300 clip nozzles
Weight:	300 kg
Control:	PLC
Air Consumption:	120 NL per minute

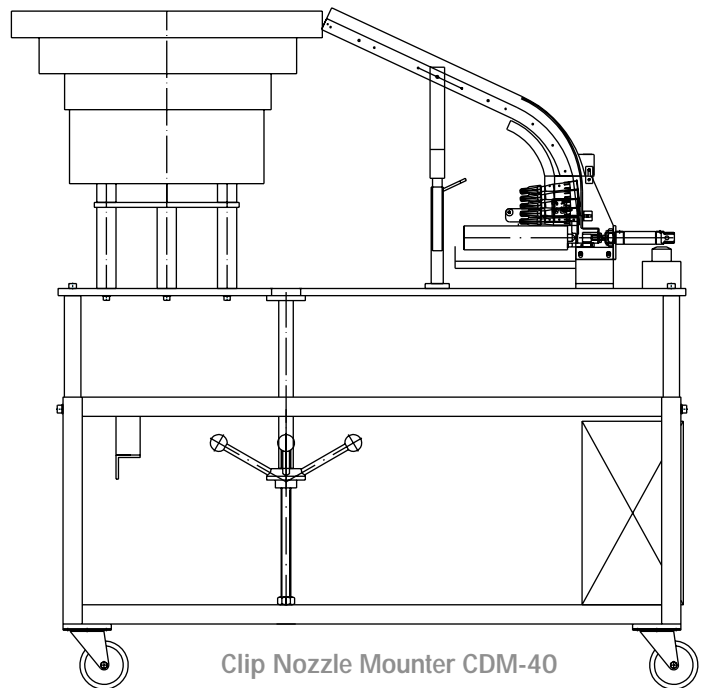
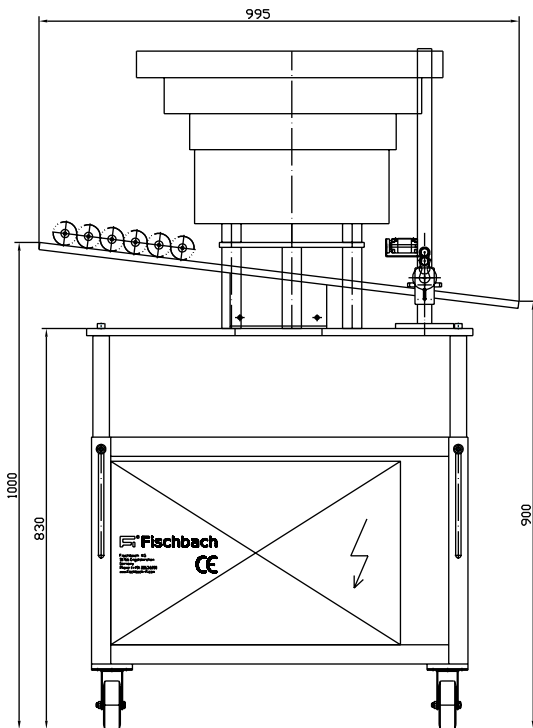

Clip Nozzle Mounter CDM-40

**Fi**® **Fischbach**



Fischbach KG  
Büchlerhausen 18  
D-51766 Engelskirchen, Germany

www.fischbach-fi.com  
Telefon: +49.2263.6090  
Telefax: +49.2263.60358

Fischbach Korea Co., Ltd.  
Telefon: +82.2.3452.3091  
Telefax: +82.2.3452.3095

Fischbach U.K. Ltd.  
Telefon: +44.1928.579320  
Telefax: +44.1928.579403

Fischbach Belgium N.V.  
Telefon: +32.3710.9621  
Telefax: +32.3710.9631

Fischbach USA Inc.  
Telefon: +1.270.769.9333  
Telefax: +1.270.769.9623

Fischbach Ibérica, S.A.  
Telefon: +34.972.168487  
Telefax: +34.972.168324

Fischbach GmbH & Co.KG  
Telefon: +49.3522.5285 0  
Telefax: +49.3522.528511