

Plungers

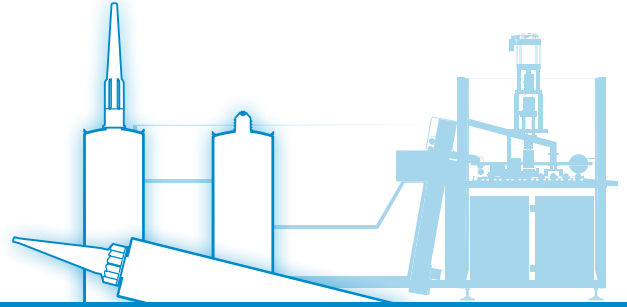

Type K 11 ST

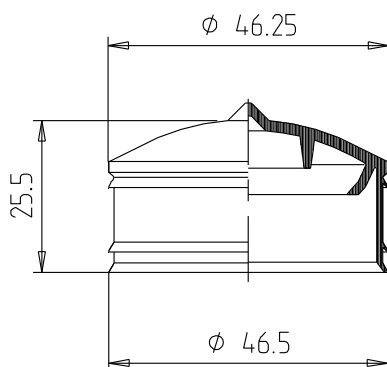

CAN BE COMBINED WITH

310 ml Fischbach cartridges

ADVANTAGEOUS FEATURES

- suitable for most sealing compounds
- good mechanical handling especially on fully automatic filling lines
- the convex plunger head enables plunger setting without trapping of air
- the inwardly slanted plunger expanding ring increases the plunger diameter during application for optimum emptying of the cartridge even at high pressing forces and with viscous masses
- mechanical and pneumatic devices can be used for applying the product
- the flexible sealing lips also create a seal against application devices that use compressed air

TECHNICAL SPECIFICATIONS

Material:	LPE
Weight:	6.7 g
Packaging unit:	1,500 Pieces/box

General tolerance: DIN 16 901-150. Subject to technical changes.

Our product recommendations are based on empirical data only and cannot replace the customer's own tests.



Fischbach KG
51766 Engelskirchen, Germany
Telefon: +49 (0) 2263 6090
Telefax: +49 (0) 2263 60358
info@fischbach-fi.com

Fischbach Korea Co., Ltd.
Songpa-Gu, Seoul, Korea
Telefon: +82 2 425 3092
Telefax: +82 2 425 3191
korea@fischbach-fi.com

Fischbach Ibérica, S.A.
17410 Sils (Girona), Spain
Telefon: +34-972-16 84 87
Telefax: +34-972-16 83 24
spain@fischbach-fi.com

Fischbach (Shanghai) Co., Ltd.
Shanghai, China 201708
Telefon: +86-21-6979-1423
Telefax: +86-21-6979-1426
china@fischbach-fi.com

Fischbach Belgium N.V.
9140 Temse, Belgium
Telefon: +32-3-710 96 20
Telefax: +32-3-710 96 31
belgium@fischbach-fi.com

Fischbach U.K. Ltd.
Cheshire WA7 1SN, Great Britain
Telefon: +44-1928-579320
Telefax: +44-1928-579403
uk@fischbach-fi.com

Fischbach USA Inc.
 Elizabethtown, Kentucky, 42701 USA
Telefon: +1-270-7 69 93 33
Telefax: +1-270-7 69 96 23
usa@fischbach-fi.com